

340_L
Capacity

136_{Kg}
Nominal load

200 / 300_{mm}
Wheels diameter



FEATURES

The body and lid are injection moulded in solid coloured high-density polyethylene.

Manufactured using environmentally-friendly recyclable materials.

No heavy metals in the pigments.

Ideal for different types of waste collection: paper and cardboard, glass, packaging, organic matter, etc. ...

Available in a wide range of colours..

DIN or AFNOR standard lifting systems.

Customisation of lid with thermal transfer graphic, area: 230 x 45 mm.

Customisation of lid with an embossed logo, area: 340 x 220 mm.

Customisation of body with silk screen or thermal transfer graphic, area: 280 x 290 mm.

CE Marking with sound power level indicated in accordance with European Directive 2000/14/EC. 78,7 db.

UN certificate for the transportation of hazardous goods.

Product Approval Certificate awarded by TÜV Product Service GmbH in accordance with European Standard EN 840.:2012

STANDARDS

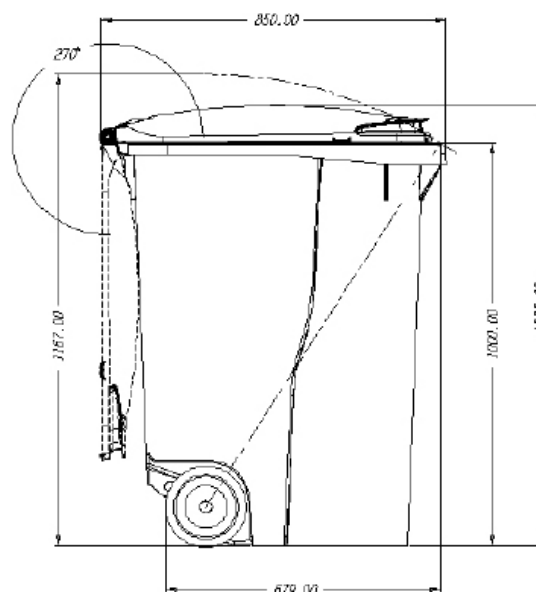
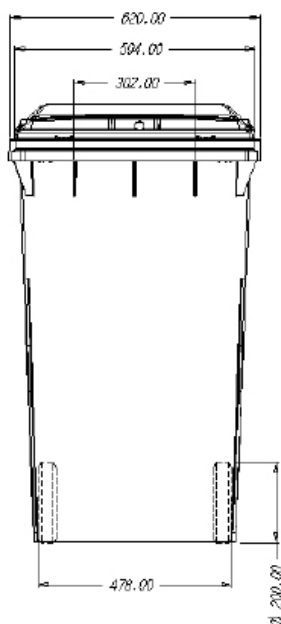

These dimensions are subject to the tolerances given in EN 840-1:2012.

ATTRIBUTES



QUALITY



ERGONOMICS



FUNCTIONALITY

ACCESSORIES



GLASS APERTURE



PLASTIC APERTURE



PAPER APERTURE



RAIN COVER



CUSTOMISATION BY
THERMAL TRANSFER
PRINTING



FOOT SUPPORT



PEDAL OPERATED LID
OPENING



AVAILABLE IN A WIDE
RANGE OF COLOURS

EQUIPMENT

200/300 mm diameter wheels.

Openings with sizes and features specially designed to accommodate each type of waste, making them easy to use.

Integrated sound-proofing system in the lid.

Recess for electronic chips.

Can be equipped with a range of accessories providing real solutions to every requirement: pedal-operated lid opening, reflective strips, lock, side handle.

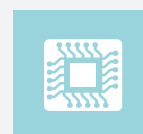

Electronic Chip

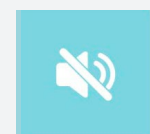

Sound-proofing

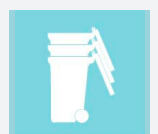

Easy to stack

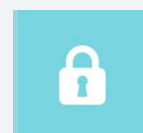

Lock



Numbering



Reflective strips