

CRANE-LIFT RANGE

# Metallic Igloo

**3000 L**

Capacity

**750 Kg**

Maximum load

**1620 mm**

Height

**1300 mm**

Openings height



## TECHNICAL SPECIFICATIONS

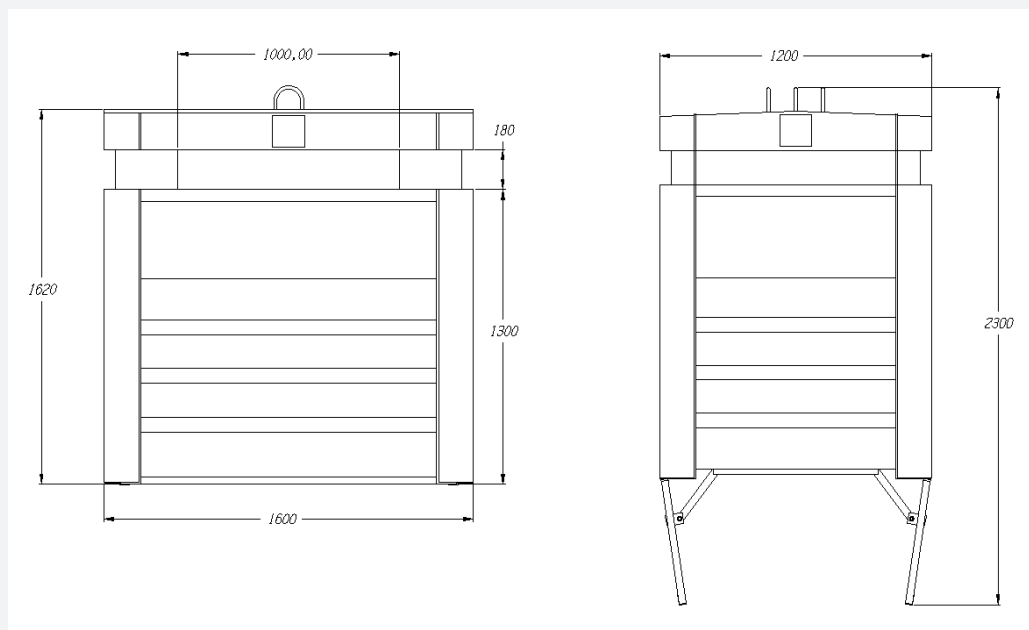

CRANE-LIFT RANGE

# Metallic Igloo

## FEATURES

- CONTENUR's Crane-lift range containers are manufactured through a rotomoulding system with high-density linear polyethylene dyed in the mass and stabilised against the combined effect of water and U.V. rays; their useful life has been extended, resulting in a highly-resistant product to atmospheric factors.
- Manufactured under the strictest international standards, they have completed demanding quality and product certification tests.
- Their design has been conceived for total integration into urban surroundings, with specific solutions for each type of waste. Available in a wide range of colours and fitted with a full set of accessories, to cover any situation that may arise in city waste collection.
- Different lifting systems available: single hook, double hook or Kinshofer.
- Thanks to their manufacturing system, materials, and design, they require little maintenance.

- The aperture is kept closed by means of a pivoting door to prevent water ingress and air ingress in the event of fire.
- Unloading system with doors that pivot sideways to allow the container to be emptied completely.
- All metal parts, welds, drill holes, etc. are hot dip galvanised and then cold galvanised to avoid rust points and to keep the product in good condition.
- Double hook lifting system.
- Paintwork is standard antirust grey RAL 7032 for the body and blue RAL 5002 for the apertures.
- Possibility of customising body of the container with shields, logos, etc. using silk screen graphic or sticker.

Front side, available dimensions:

- 1240 x 140 mm
- 1240 x 170 mm
- 1240 x 240 mm

Back side, available dimension: 850 x 240 mm

- Customised containers for each type of waste collection: glass, paper, plastics, etc.

Circular openings, available diameters:

- Ø250 mm
- Ø300 mm

Rectangular opening, available dimension:

- 1000 x 180 mm

## EQUIPMENT AND ACCESSORIES

- Metallic container for paper and cardboard collection with a capacity of 3 m<sup>3</sup>.
- Galvanised plate steel body with single piece, cold drawn corner columns.
- The side panels are welded to the columns, and are folded to provide extra strength.



CUSTOMISATION WITH SILK SCREEN GRAPHIC



CUSTOMISATION WITH STICKER